

A top performer



Mikron Multistar CX-24

Mikron Multistar CX-24

A top performer!

What makes the Multistar CX-24 so special? It's unbeatably precise performance and speed. The Multistar CX-24 transfer machine supports serial production of part families and workpieces which demand perfect processing. The Multistar CX-24 is precise, fast, versatile and customizable – simply a top performer!

What else do you need?

The Multistar CX-24 controls the spindle movements via linear curves. The quickly changeable control curves provide processing flexibility. The highly productive rotary transfer machines work economically, even with quantities of only a few thousand workpieces per parts variation. What else? The precise interplay of all elements assures faultless processing quality, even when used over a long period of time. 24 additional intermediate stations allow measuring, controlling and cleaning procedures in the processing cycle.

One identity, two types

There are two types of the Multistar CX-24: a monoblock and an adjustable version. The rigid monoblock version is suitable for workpieces with mainly centric operations. Does your part need off-center and/or sloping processing? No problem. We have installed the working spindles in adjustable stations which increases the flexibility of the machine. Another advantage, Multistar CX with adjustable stations also allows the turning of partly processed workpieces into clamping systems with a different shape or diameter.

Advantages at a glance

- Precise serial production of part families and demanding workpieces
- $\pm 2.5 \mu\text{m}$ table index repeatability
- 24 stations with up to 44 machining units allow very high output rate

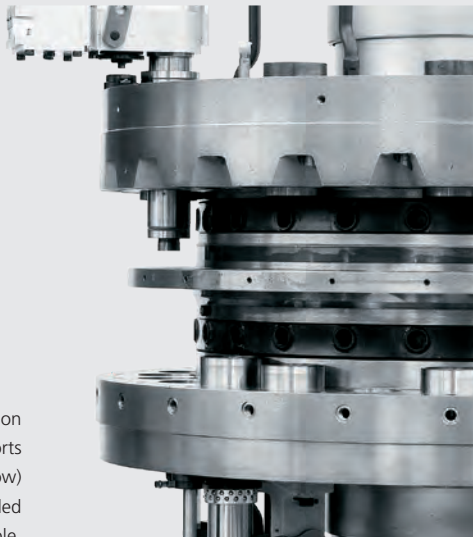

Monoblock station supports (above and below) with embedded indexing table.



adjustable work station supports (above and below) with embedded indexing table.

Mikron Multistar CX-24 an exceptional mechanism

Thanks to the exclusive cinematic (Mikron patent), Multistar is able to perfectly drive up to 48 machining units from above, below or horizontally and also for loading / unloading operations. Your advantages:

- Long-life and reliability
- High productivity
- Perfect accuracy and repeatability

Each machining unit has its independent linear curve, in order to quickly adapt the system to each different parts of a family. Your benefit:

- Fast changeover between parts of a family
- Perfect surface finish and long life of cutting tools since each unit is set to the optimal tool feed

Multistar is the only machining system that can be equipped with up to 48 clamping collets: 24 main collets and 24 additional collets with different section. This exclusive allows the part to be turned-over and clamped on different section/sides of the part. Example:

- A square section blank is fixed in the collet and turning operations are made.
- The part is turned-over and fixed in an alternative collet, this time with a round section, for the machining of the other side of the part.



Part turn-over in different section collet



Up to 44 units work for you simultaneously.

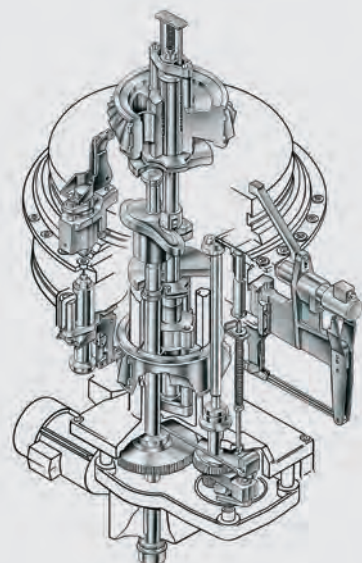

Multistar CX-24 cinematic

Mikron Multistar CX-24

A top performer!

Spring chucks, a strategic element

Developed and manufactured by Mikron, the Multistar spring chucks fit perfectly to the machine concept.

Special features

- Safety: The chuck clamping force which is equally distributed on the parts outer edges, always ensures that the workpieces will not become deformed.
- Precision: Precise and compact spring chucks guarantee highly accurate repeatability in few μm .
- Productivity: Compact construction allows for a higher concentration of spring chuck in a tight space.
- Versatility: Ideal for round and randomly profiled parts with precise outer edges, up to a diameter of 30 mm.
- Orientation: The spring chucks can be turned to any position for transverse machining.
- Rotation: Rotating spring chucks ensure perfect concentricity for turning and plunge cutting operations.



Some Multistar CX-24 units at one glance

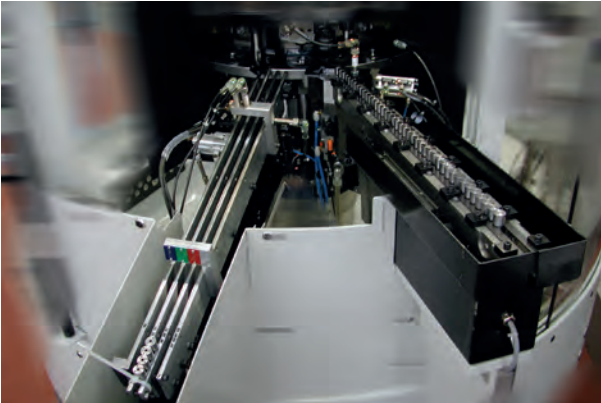

Loading / unloading unit

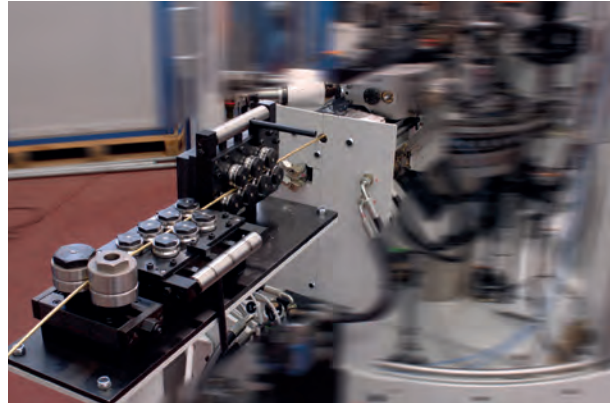

Wire coil feeding device incl straightening & cutting



Machining units operating from all directions



Part turn-over unit

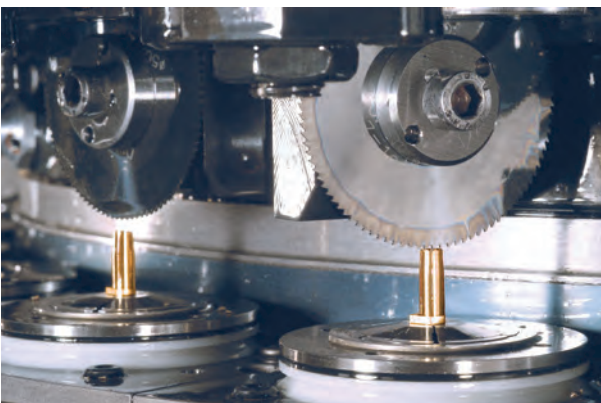

Vertical milling unit

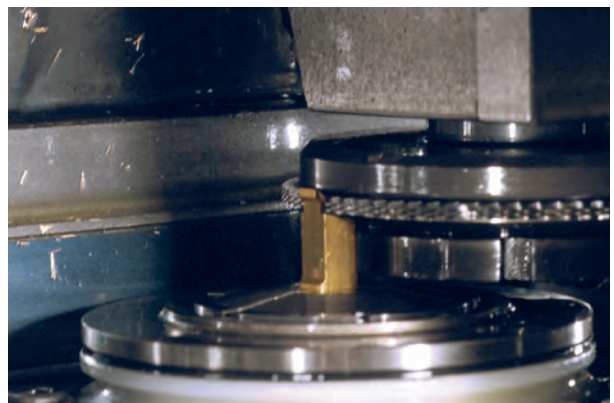

Horizontal milling unit

CASE HISTORY Air Spring Valves (Ventless Molds)

On Mikron Multistar CX-24

The challenge

- **30+30 million parts per year**
- 2 pieces made in steel, with turning, drilling & milling operations
- Production of male & female component simultaneously on the same machine
- Tolerances: $\pm 10\mu\text{m}$ on diameters
- Raw material supply from wire coil (instead from bar-stock)



The traditional solution

Production area: **136.2 m²**



Required machines: **16**



Employees: **3.2 + 3.2 + 3.2**



Cost/part



Raw material from bar-stock

Mikron: The innovative solution

Production area: **38.64 m²**



Required machines: **1 Mikron Multistar CX-24**



Employees: **0.5 + 0.5 + 0.5**



Cost/part



Raw material from wire coil

Your advantage

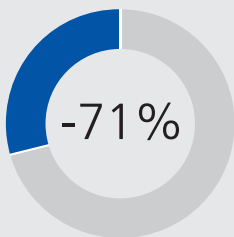

Production area

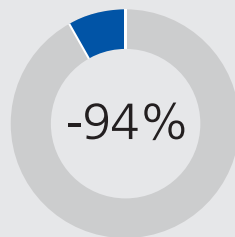

Machines

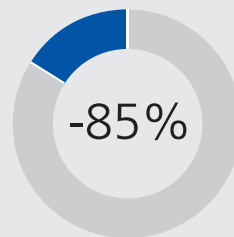

Employees

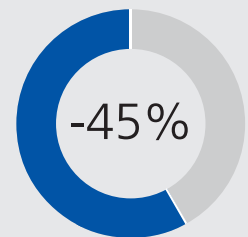

Cost/part

Technical Data Multistar CX-24

Machine

Number of stations		24
Max. number of upper units		23
Max. number of lower units		22
Max. number of lateral units		22
Number of clamping fixtures		24 / 48
Table position repeatability	µm	± 2.5
Table indexing time	sec	0.4
Max workpiece dimension	mm	∅ 30 L65
Max. cycles	pcs/min.	70
Multiple cycle up to	pcs/min.	280

Clamping devices

Min. clamping diameter	mm	0.6
Max. clamping diameter	mm	30
Max. clamping diameter indexable	mm	24
Max. clamping diameter rotating	mm	15

Machining units

Max. machining length	mm	53
Central cam for working feed (machining units)		no
Linear cam for working feed (machining units)		yes
Multistar CX-24 CNC version		yes, max 20 axis
Chuck indexing for workpiece machining around 360°		yes
Rotation of workpiece (chuck drive), speed adjustable	rpm	6'000

Machining spindles

Spindle speed	rpm	23'000
Spindle diameter	mm	40
Max. spindle rating	kW	1

Installation

Main drive power	kW / Hz	5.5 / 50
Input voltage	V	400
Power consumption ca.	kW	15 - 30
Pressure of compressed air	bar	5
Consumption	m ³ /h	10 - 20
Approx. weight of machine	kg	4500
Dimensions L x D x H	m	1.95x5.2x2.9
when machining from wire	m	1 + 2



The technical data listed are not binding and may be changed at any time without notice.

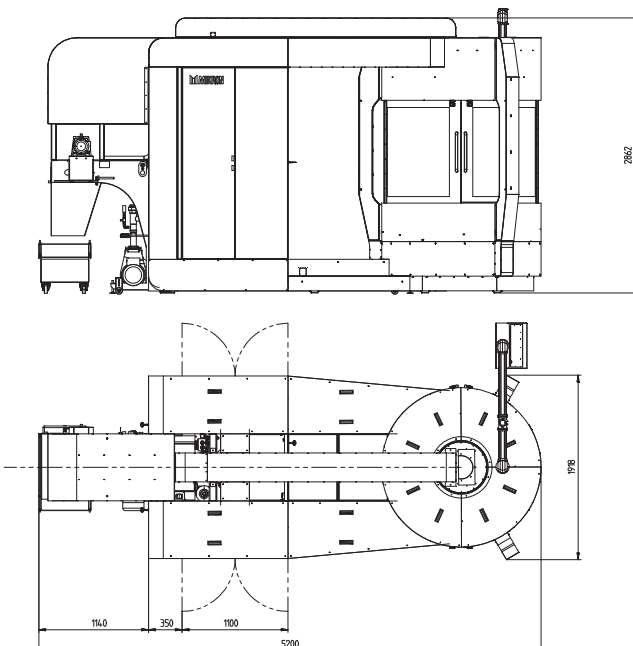

Mikron Machining

Mikron Switzerland AG, Agno

Division Machining

Headquarter
Via Ginnasio 17
6982 Agno
Switzerland
Tel. +41 91 610 61 11
Fax +41 91 610 66 80
mag@mikron.com

Mikron GmbH Rottweil Berner

Feld 71
D-78628 Rottweil
Tel. +49 741 5380 0
Fax +49 741 5380 580
mro@mikron.com

Mikron Corp. Monroe

200 Main Street
P.O. Box 268
Monroe, CT 06468 / USA
Tel. +1 203 261 31 00
Fax +1 203 268 47 52
mmo@mikron.com

