



CHMER EDM

Electric Discharge Machine



Rising Star Award



National Award



IT'S VERY WELL
MADE IN TAIWAN



CM H30A

CM H32A



CM H86A

CHING HUNG MACHINERY & ELECTRIC INDUSTRIAL CO., LTD.

FEATURE:

- Make starting holes for wire-cutting.
- Drill small & deep holes on extra hard steel, alloy, metallizer, powder metallurgy and on metals that ordinary drilling machine unable to work on.
- Able to drill small & deep holes on spherical curved and irregular working surface.
- Work table is made of stainless steel.
- Z axis equipped with precise ballscrew to obtain high stability and high speed machining.
- Material for electrode tube can be either brass or copper.
- Dielectric fluid can be either water or distilled water, as far as low cost is concerned.
- Sodick patents licensed.

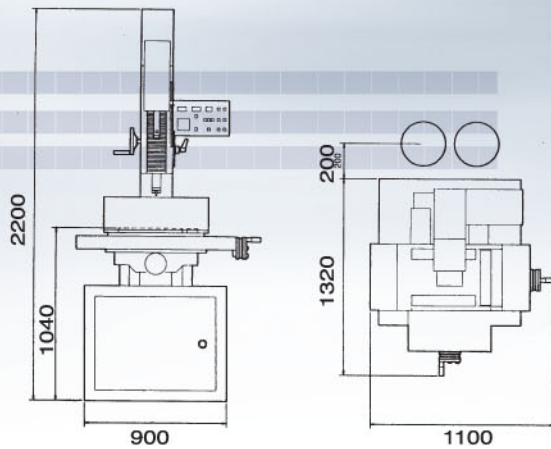

SPECIFICATIONS:

MACHINE UNIT	UNIT	CM H30A	CM H32A	CM H86A
Max. workpiece size (W x D x H)	mm	650x300x250 (25.6x11.8x9.8)	800x450x340 (31.4x17.7x13.3)	740x1140x350 (29.1x44.8x13.7)
Max. workpiece weight	kgs/lbs	100 (220.4)	100 (220.4)	1500 (3300)
Table travel (X, Y)	mm/in	300x200 (11.8x7.9)	350x250 (13.8x9.8)	600x800 (23.6x31.4)
Ram travel (Z1)	mm/in	340 (13.3)	340 (13.3)	340 (13.3)
Ram travel (Z2)	mm/in	*	200 (7.9)	*
Machine head movement	mm/in	150 (5.9)	150 (5.9)	150 (5.9)
Electrode pipe Diameter	mm/in	Ø0.2 ~ Ø3.0 (one unit/0.1)	Ø0.2 ~ Ø3.0 (one unit/0.1)	Ø0.2 ~ Ø3.0 (one unit/0.1)
Max. electrode pipe length	mm/in	400 (15.7)	400 (15.7)	400 (15.7)
Distance from table to bottom of guide holder	mm/in	53~196 (2.1~7.7)	0~353 (0~13.8)	160~313 (6.2~12.3)
Fluid capacity	L	25 liter x2	25 liter x2	90
Machining fluid		Water	Water	Water
Outside dimensions (W x D x H)	mm/in	1000x1030x2200(39.3x40.5x86.6)	1380x1110x2360 (54.3x43.7x92.9)	1200x1450x2160 (47.2x57.1x85.1)
Net weight	kgs/lbs	550 (1210)	600 (1320)	2000 (4400)

• Information subject to change without notice.

STANDARD ACCESSORIES DELIVERED WITH THE MACHINE:

- Guide dia. 1.0 Mmx1
- Electrode brass tube dia. 1.0X400 mmx10
- Insert rubbers dia. 1.0 Mmx3
- Guide dia. 0.5Mmx1
- Insert rubbers dia. 0.5 Mmx3
- Electrode brass tube dia. 0.5X400 mmx10
- Tool boxx1
- Paint sparex1
- Machine padx3
- Flushing pipex1
- Filterx1
- Flushing nozzlex1
- Air fast connectorx1
- Set of allen spannerx1
- Handle for filtercapx1

OPTION :

- ER spindle
- Ce conformity

POWER SUPPLY	CM H30A	CM H32A	CM H86A
Input power source	3 KVA		
Pulse generation system	Power FET switching		
Max. machining current	25		
Machining current selection	8 steps (1-8)		
Pluse width setting	10 steps (0-9)		



CHING HUNG MACHINERY & ELECTRIC INDUSTRIAL CO., LTD.

No. 28, Lane 229, Sec.1 Jhongshan RD., Wurih Township, Taichung County, Taiwan, R.O.C.

TEL: 886-4-23373515 FAX: 886-4-23370718

URL: <http://www.chmer.com> E-mail: overseas@mail.chmer.com